

SPS Series

6.6kW Programmable DC Power Supply



FEATURES

- 3U Rack Height
- Wide range available, up to 800V & 800A
- GPIB/SCPI, RS232, Ethernet & USB Interface available
- Closed case calibration
- LED Display module
- Programmable protection modes
- TTL on-off control
- Master/slave capability, up to 31 channels available
- Modifications possible

ENVIRONMENTAL

Storage Temp:	-40°C to +70°C
Operating Temp:	0°C to +50°C
Humidity:	0 to 80% RH Non-condensing

SAFETY / EMC

EN60950
CE marked in accordance with the
Low Voltage Directive (LVD)

UL approved to UL60950

ELECTRICAL SPECIFICATIONS

INPUT

AC INPUT	208/240VAC 3-phase
(Auto switching)	380/415VAC 3-phase
	440/480VAC 3-phase

Frequency	50 - 60Hz
-----------	-----------

OUTPUT

Line Regulation	±0.05% - CV or CC mode
Load Regulation	±0.05% - CV or CC mode
Transient Response (1)	10mS
Stability (2)	±0.01% +10mV
Temp. Coefficient (3)	0.04% / °C of max. output I
Output Isolation	2500VDC

Built in Interface	RS 232
--------------------	--------

NOTES:

1. 30% load change within 2% of nominal voltage
2. Under constant load, line & temp. over an 8 hour interval after a 30 min. warm up period
3. After 30 min. warm up period

Specifications subject to change without notice

Safety Power Group Ltd

9, Farnborough Business Centre, Eelmoor Road, Farnborough, Hampshire. GU14 7QN

Tel: +44 (0) 1252 515565 Fax: +44 (0) 1252 546021

e-mail: sales@safety-power.com web: www.safety-power.com

AVAILABLE MODELS

MODEL No.	OUTPUT VOLTAGE	OUTPUT CURRENT
SPS8-800	0 - 8VDC	0 - 800ADC
SPS10-600	0 - 10VDC	0 - 600ADC
SPS16-400	0 - 16VDC	0 - 400ADC
SPS20-330	0 - 20VDC	0 - 330ADC
SPS32-200	0 - 32VDC	0 - 200ADC
SPS40-165	0 - 40VDC	0 - 165ADC
SPS60-110	0 - 60VDC	0 - 110ADC
SPS80-82	0 - 80VDC	0 - 82ADC
SPS100-66	0 - 100VDC	0 - 66ADC
SPS125-53	0 - 125VDC	0 - 53ADC
SPS160-41	0 - 160VDC	0 - 41ADC
SPS200-33	0 - 200VDC	0 - 33ADC
SPS250-26	0 - 250VDC	0 - 26ADC
SPS375-17	0 - 375VDC	0 - 17ADC
SPS500-13	0 - 500VDC	0 - 13ADC
SPS600-10	0 - 600VDC	0 - 10ADC
SPS800-8	0 - 800VDC	0 - 8ADC

ORDERING INFORMATION

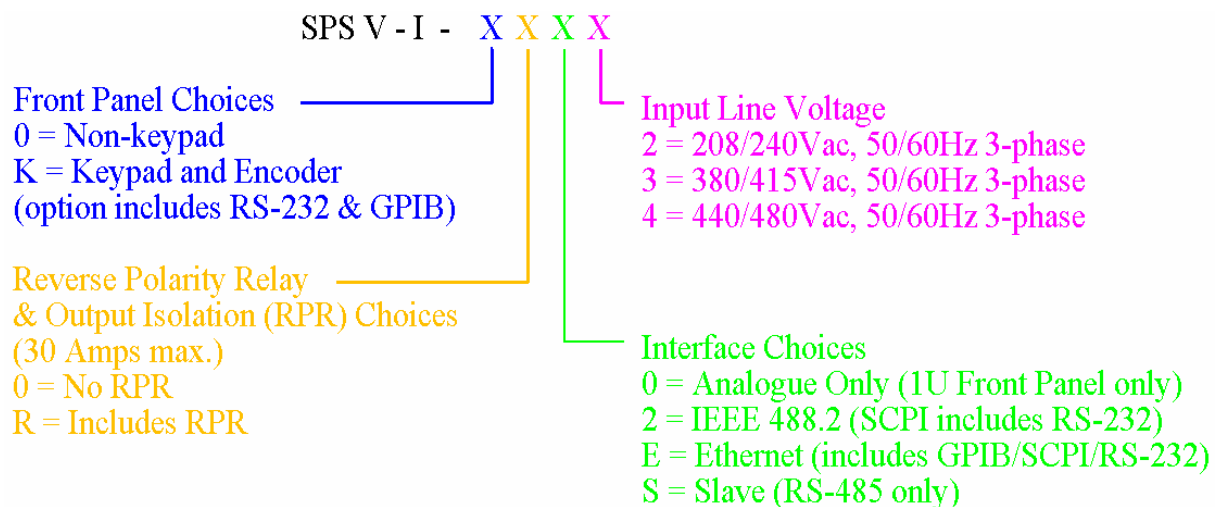

Specifications subject to change without notice

Safety Power Group Ltd

9, Farnborough Business Centre, Eelmoor Road, Farnborough, Hampshire. GU14 7QN

Tel: +44 (0) 1252 515565 Fax: +44 (0) 1252 546021

e-mail: sales@safety-power.com web: www.safety-power.com