

# SPS Series

## 10kW Programmable DC Power Supply



### FEATURES

- 3U Rack Height
- Wide range available, up to 800V & 900A
- GPIB/SCPI, RS232, Ethernet & USB Interface available
- Closed case calibration
- LED Display module
- Programmable protection modes
- TTL on-off control
- Master/slave capability, up to 31 channels available
- Modifications possible

### ENVIRONMENTAL

Storage Temp:	-40°C to +70°C
Operating Temp:	0°C to +50°C
Humidity:	0 to 80% RH Non-condensing

### SAFETY / EMC

EN60950  
CE marked in accordance with the  
Low Voltage Directive (LVD)

UL approved to UL60950

### ELECTRICAL SPECIFICATIONS

#### INPUT

AC INPUT	208/240VAC 3-phase
(Auto switching)	380/415VAC 3-phase
	440/480VAC 3-phase

Frequency	50 - 60Hz
-----------	-----------

#### OUTPUT

Line Regulation	±0.05% - CV or CC mode
Load Regulation	±0.05% - CV or CC mode
Transient Response (1)	10mS
Stability (2)	±0.01% +10mV
Temp. Coefficient (3)	0.04% / °C of max. output I
Output Isolation	2500VDC

Built in Interface	RS 232
--------------------	--------

#### NOTES:

1. 30% load change within 2% of nominal voltage
2. Under constant load, line & temp. over an 8 hour interval after a 30 min. warm up period
3. After 30 min. warm up period

Specifications subject to change without notice

#### Safety Power Group Ltd

9, Farnborough Business Centre, Eelmoor Road, Farnborough, Hampshire. GU14 7QN

Tel: +44 (0) 1252 515565 Fax: +44 (0) 1252 546021

e-mail: sales@safety-power.com web: www.safety-power.com

## AVAILABLE MODELS

MODEL No.	OUTPUT VOLTAGE	OUTPUT CURRENT
SPS10-900	0 - 10VDC	0 - 900ADC
SPS16-600	0 - 16VDC	0 - 600ADC
SPS20-500	0 - 20VDC	0 - 500ADC
SPS32-300	0 - 32VDC	0 - 300ADC
SPS40-250	0 - 40VDC	0 - 250ADC
SPS60-166	0 - 60VDC	0 - 166ADC
SPS80-125	0 - 80VDC	0 - 125ADC
SPS100-100	0 - 100VDC	0 - 100ADC
SPS125-80	0 - 125VDC	0 - 80ADC
SPS160-62	0 - 160VDC	0 - 62ADC
SPS200-50	0 - 200VDC	0 - 50ADC
SPS250-40	0 - 250VDC	0 - 40ADC
SPS375-27	0 - 375VDC	0 - 27ADC
SPS500-20	0 - 500VDC	0 - 20ADC
SPS600-16	0 - 600VDC	0 - 16ADC
SPS800-12	0 - 800VDC	0 - 12ADC

## ORDERING INFORMATION

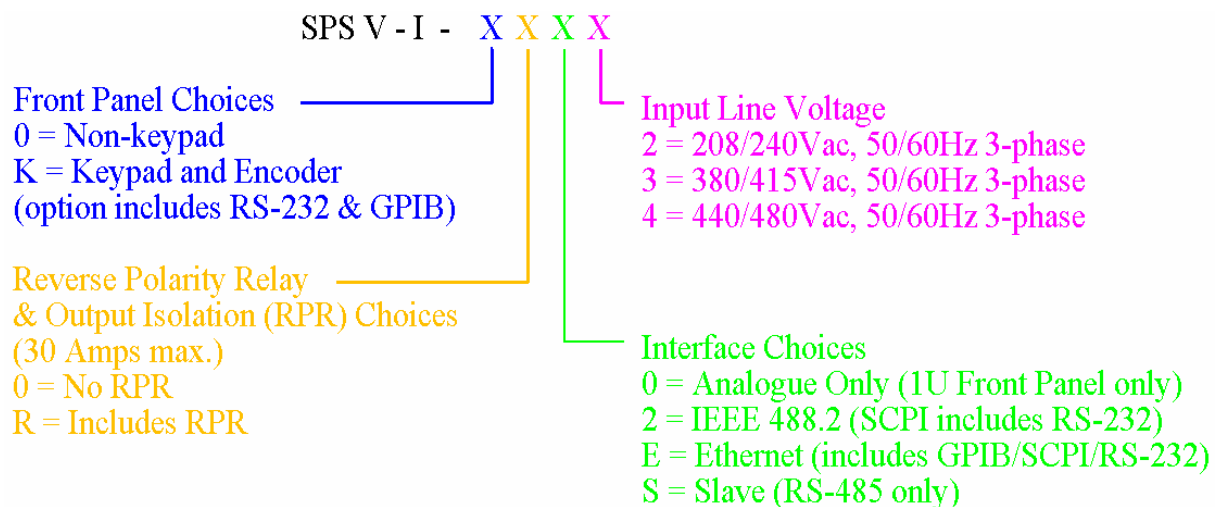

Specifications subject to change without notice

### Safety Power Group Ltd

9, Farnborough Business Centre, Eelmoor Road, Farnborough, Hampshire. GU14 7QN

Tel: +44 (0) 1252 515565

Fax: +44 (0) 1252 546021

e-mail: sales@safety-power.com

web: www.safety-power.com