

SPS Series

1.2kW Programmable DC Power Supply



FEATURES

- High Power Density, 1U
- Multi channel output available
- GPIB/SCPI, RS232, Ethernet & USB interface available
- Closed case calibration
- 10 turn potentiometer for voltage & current control
- LED display module
- Programmable protection modes
- TTL on-off control
- Master/slave capability up to 31 channels available

ENVIRONMENTAL

Storage Temp:	-40°C to +70°C
Operating Temp:	0°C to +50°C
Humidity:	0 to 80% RH Non-condensing

SAFETY / EMC

EN60950
CE marked in accordance with the
Low Voltage Directive (LVD)

UL approved to UL60950

ELECTRICAL SPECIFICATIONS

INPUT

AC INPUT	104 - 130VAC / 20A max.
(Auto switching)	207 - 260VAC / 10A max.
Frequency	47 - 63Hz

OUTPUT

Line Regulation	±0.05% - CV or CC mode
Load Regulation	±0.05% - CV or CC mode
Transient Response (1)	1 - 3mS
Stability (2)	±0.01% +10mV
Temp. Coefficient (3)	100ppm / °C (CV mode) 300ppm / °C (CC mode)
Output Isolation	±600VDC
Remote Sense	±2VDC volt drop / line
Meter Accuracy	0.2% +0.2V (Voltage) 0.2% +0.2A (Current)

NOTES:

1. 50% to 100% load change within 0.1% of nominal voltage
2. Under constant load, line & temp. over an 8 hour interval after a 30 min. warm up period
3. After 30 min. warm up period

Specifications subject to change without notice

Safety Power Group Ltd

9, Farnborough Business Centre, Eelmoor Road, Farnborough, Hampshire. GU14 7QN

Tel: +44 (0) 1252 515565

Fax: +44 (0) 1252 546021

e-mail: sales@safety-power.com

web: www.safety-power.com

AVAILABLE MODELS

MODEL No.	OUTPUT VOLTAGE	OUTPUT CURRENT
SPS8-150	0 - 8VDC	0 - 150ADC
SPS20-60	0 - 20VDC	0 - 60ADC
SPS35-35	0 - 35VDC	0 - 35ADC
SPS40-30	0 - 40VDC	0 - 30ADC
SPS60-20	0 - 60VDC	0 - 20ADC
SPS80-15	0 - 80VDC	0 - 15ADC
SPS120-10	0 - 120VDC	0 - 10ADC
SPS150-8	0 - 150VDC	0 - 8ADC
SPS200-6	0 - 200VDC	0 - 6ADC
SPS300-4	0 - 300VDC	0 - 4ADC
SPS450-2.5	0 - 450VDC	0 - 2.5ADC
SPS600-2	0 - 600VDC	0 - 2ADC

ORDERING INFORMATION

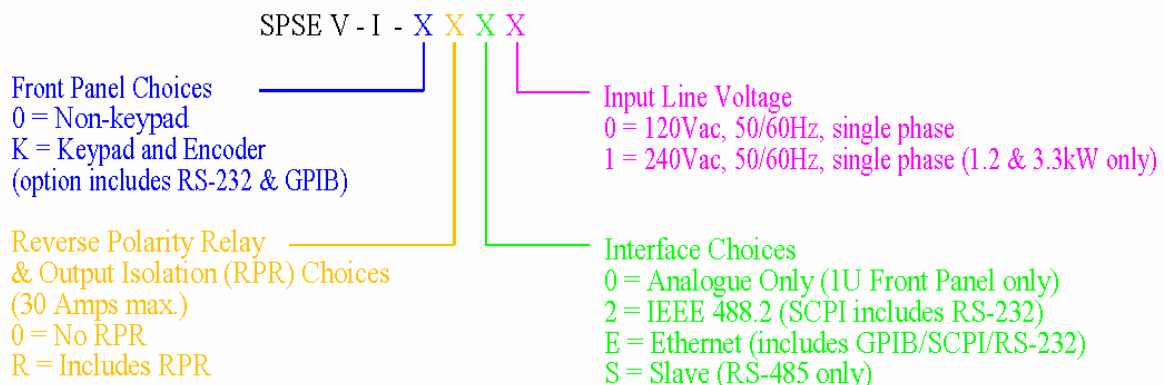

Specifications subject to change without notice

Safety Power Group Ltd

9, Farnborough Business Centre, Eelmoor Road, Farnborough, Hampshire. GU14 7QN

Tel: +44 (0) 1252 515565

Fax: +44 (0) 1252 546021

e-mail: sales@safety-power.com

web: www.safety-power.com