

DELTA



SAFETY POWER
PO BOX 365 GUILDFORD
SURREY GU4 7RF
TEL. +44(0)1483 225482
FAX +44(0)1483 225492



ES150 - series 150 watts DC POWER SUPPLIES



ES 015-10	0 - 15 V	0 - 10 A
ES 030-5	0 - 30 V	0 - 5 A
ES 075-2	0 - 75 V	0 - 2 A
ES 0300-0.45	0 - 300 V	0 - 450 mA

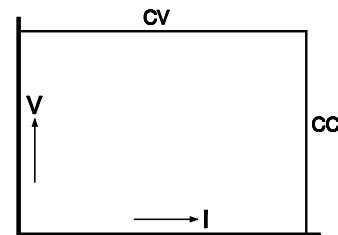

- 4 mm Safety Sockets
- Weight only 1.7 kg
- Wide input voltage range:
90 - 265 VAC, 48 - 62 Hz or 125 - 380 VDC
- Active Power Factor Correction
- Efficiency up to 84 %
- 0 - 5 V analog programmable
(on both voltage and current)
- Isolated analog programming with optional
ISO AMP MODULE to prevent earth loops
- Programming Inputs and Monitoring Outputs have
a very low offset
- **RS232 or IEEE488** with optional external inter-
face PSC 232 or PSC 44M
- Very low output ripple
- Stable output voltage or current
- Input / output insulation 3750 V rms
- EMC: high immunity and low emission
- Designed for long life at full power
- Protected against all overload and short circuit
conditions
- Voltage and current control with 10 turn
potentiometers, resolution 0.03 %
- Optional rear panel output connection
(option includes remote sensing)
- 48 hours burn-in

	ES 015-10	ES 030-5	ES 075-2	ES 0300-0.45
Output voltage current	0 - 15 V 0 - 10 A	0 - 30 V 0 - 5 A	0 - 75 V 0 - 2 A	0 - 300 V 0 - 450 mA
Input AC single phase, 48 - 62 Hz Input current @ 230 VAC power factor, 110 / 230 VAC full load DC internal fuses standby input power (Vo=Io=0) standby input power (Vo=Vmax)			90 - 265 V 1 A 0.99 / 0.83 125 - 380 V 4 AT 6 W 11 W	
Efficiency AC 230 V input, full load AC 110 V input, full load DC 230 V input, full load	83 % 80 % 83 %	84 % 82 % 84 %	84 % 81 % 84 %	84 % 81 % 84 %
Regulation				
Load 0 - 100% CV internal sensing optional external sensing	15 mV 2 mV	6 mV 2 mV	5 mV 5 mV	10 mV 10 mV
Line 90 - 265 V AC CV	0.2 mV	0.5 mV	1 mV	3 mV
Load 0 - 100% CC Line 90 - 265 V AC CC (internal voltage sensing)	3 mA 0.5 mA	1 mA 0.2 mA	0.5 mA 0.1 mA	0.3 mA 0.05 mA
Ripple + noise (full load) rms (BW=300 kHz) CV p-p (BW=50 MHz) CV rms (BW=300 kHz) CC p-p (BW=50 MHz) CC	0.5 mV 8 mV 1.5 mA 10 mA	0.6 mV 10 mV 0.5 mA 2 mA	1 mV 15 mV 0.1 mA 0.5 mA	7 mV 50 mV (typical 30 mV) 0.03 mA 0.2 mA
Temp. coeff., per °C CV CC			10.10 ⁻⁵ 10.10 ⁻⁵	
Stability after 1 hr warm-up during 8 hrs CV CC tamb = 25 ± 1 °C, Vin = 230 VAC (internal voltage sensing for CC-stab.)	10.10 ⁻⁵ 10.10 ⁻⁵	10.10 ⁻⁵ 10.10 ⁻⁵	10.10 ⁻⁵ 10.10 ⁻⁵	10.10 ⁻⁵ 12.10 ⁻⁵

Analog Programming	CV	CC
Programming inputs input range accuracy offset temp. coeff. offset input impedance	0 - 5 V ± 0.2% 0 ... + 3 mV (on 5 V) 10 µV / °C 1 MOhm	0 - 5 V ± 0.8% 0 ... + 10 mV (on 5 V) 60 µV / °C 1 MOhm
Monitoring output output range accuracy offset temp. coeff. offset output impedance	0 - 5 V ± 0.2% - 1 ... + 1 mV (on 5 V) 10 µV / °C 2 Ohm / max. 4 mA	0 - 5 V ± 0.8% - 10 ... 0 mV (on 5 V) 60 µV / °C 2 Ohm / max. 4 mA

Reference voltage on prog. connector TC	Vref	5.137 ± 10 mV (Ro = 2 Ohm, max. 4 mA) 50 ppm
+12 V output on prog. Connector	Vo Ro	12 V ± 0.5 V 100 Ohm

Status output CC - status	CC - operation	5 V / 5 mA = logic 1
Remote shutdown	with + 5 V, 1 mA or relay contact	
Indicators (front panel)	CV-mode, CC-mode	
Controls (front panel)	Mains on/off, CV- and CC-potmeter	

Programming speed (resistive load)	ES 015-10	ES 030-5	ES 075-2	ES 0300-0.45
Rise time (10 - 90%) output voltage step time, (100% load) time, (10% load)	0 → 15 V 7 ms 3 ms	0 → 30 V 15 ms 6 ms	0 → 75 V 17 ms 7 ms	0 → 300 V 10 ms 4 ms
Fall time (90 - 10%) output voltage step time, (100% load) time, (10% load)	15 → 0 V 7 ms 70 ms	30 → 0 V 15 ms 150 ms	75 → 0 V 17 ms 160 ms	300 → 0 V 10 ms 100 ms

For High Speed versions consult factory.

	ES 015-10	ES 030-5	ES 075-2	ES 0300-0.45
Recovery time recovery within di/dt of load step time, @ 50 - 100% load step max. deviation @ 230 VAC input voltage	50 mV 250 mA/μs 100 μs 160 mV	50 mV 125 mA/μs 100 μs 160 mV	50 mV 70 mA/μs 100 μs 150 mV	50 mV 6 mA/μs 100 μs 500 mV
Output impedance CV, 0-100 kHz	< 100 mOhm	< 200 mOhm	< 250 mOhm	< 5 Ohm
Pulsating load max. tolerable AC component of load current f > 1 kHz f < 1 kHz	2 A rms 10 A peak	2 A rms 5 A peak	2 A rms 2 A peak	2 A rms 0.45 A peak

Insulation input / output creepage / clearance input / case output / case	3750 Vrms (1 min.) 8 mm 2500 Vrms 600 V DC
Safety	EN 60950 / EN 61010
EMC Emission Immunity	EN50081-1 , EN55022B, EN61000-3-2, EN60555-2, EN61000-3-3 EN50082-1 , EN50082-2 , EN61000-4-2-lv3, EN61000-4-4-lv4, ENV50140-lv3, ENV50141-lv3, ENV50204-lv3, EN61000-4-5-lv3-diff-mode-on-output, EN61000-4-5-lv2-comm-mode-on-output, EN61000-4-5-lv4-on-input, EN61000-4-11 (lv=level)
Operating Temperature at full load	- 20 to + 50 °C derate output to 75% at 60 °C
Humidity	max. 95% RH, non condensing, up to 40 °C max. 75% RH, non condensing, up to 50 °C
Storage temperature	- 40 to + 85 °C
Thermal protection	Output shuts down in case of insufficient cooling
MTBF	500 000 hrs

Hold-Up time (230 VAC input) Vout = 100% , Iout = 100% Vout = 85% , Iout = 100% Vout = 100% , Iout = 50%	25 ms 40 ms 60 ms
Turn on delay (230 VAC input) after mains switch on	250 ms
Inrush current	10 A with NTC resistor 30 Ohms cold resistance

	ES 015-10	ES 030-5	ES 075-2	ES 0300-0.45
Series operation max. total voltage Master / Slave operation	600 V with optional external Master/Slave Adapter			
Parallel operation max. total current Master / Slave operation	no limit max. 4 units			
Remote sensing (optional)	option P119	option P120	option P121	option P122
max. voltage drop per load lead	2 V <i>Note: voltage drop across load leads will subtract from max. available output voltage</i>			
Over Voltage Limit (fixed)	max. 18 V	max. 40 V	max. 90 V	max. 330 V
Potentiometers front panel control with knobs resolution screwdriver adjustment at front panel	standard 0.03% option P001			
Meters scale voltage scale current accuracy V-meter accuracy A-meter	3.5 digit 0 - 15.00 V 0 - 10.00 A 0.5% + 2 digits 1% + 2 digits	3.5 digit 0 - 30.0 V 0 - 5.00 A 0.5% + 2 digits 1% + 2 digits	3.5 digit 0 - 75.0 V 0 - 2.00 A 0.5% + 2 digits 1% + 2 digits	3.5 digit 0 -300 V 0 - 450 mA 0.5% + 2 digits 1% + 2 digits

Input Connector	Euro-connector at rear panel 10 Amp / 65 °C IEC320/C14, EN60320/C14
Output Terminals	Standard: 4 mm safety sockets at front-panel Option: screw terminals (0.2-4 mm ²) at rear-panel (sockets at front removed) only combined with remote sensing, see remote sensing for option numbers (P119 - 122)
Programming connector	15 pole D-connector at rear panel (FEMALE)
Cooling	Convection cooling
Enclosure degree of protection	IP20
Dimensions (h x w x d)	52 x 222 x 202 mm
Weight	1.7 kg

CV = Constant Voltage OVL = Over Voltage Limit = Specifications measured at $t_{amb} = 25 \pm 5^\circ C$ and
 CC = Constant Current OVP = Over Voltage Protection $V_{in} = 230 VAC, 50 Hz$ unless otherwise noted.

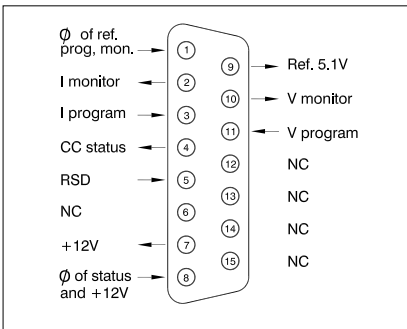

connections programming connector



19" rack adapters, height 2U

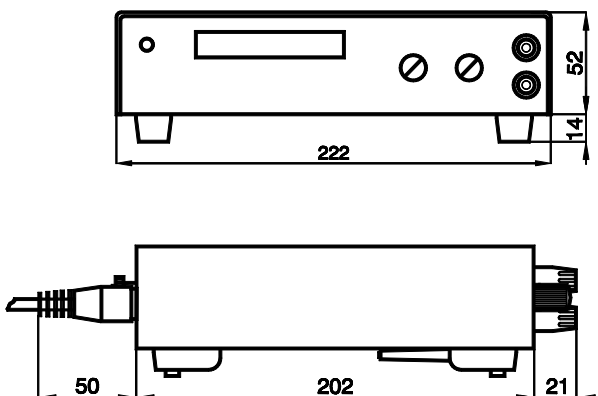

dimensions

